

ARES® Alerting Using the 1750 Hz European Burst Tone

By Chuck Rexroad, AB1CR and Rod Lane, N1FNE

Introduction

One of the biggest questions faced by ARES is “How do we alert ARES members to an emergency if the phones are out?” As the Connecticut ARES Leadership studied this question we pondered several solutions. We decided to use the European 1750 Hz Burst Tone. It will pass through any repeater as it is in the voice pass-band, and it is easily generated by many modern radios. It is easy to setup a tone decoder to determine when the tone is being sent through a repeater or simplex frequency. We decided to pursue this idea using a tone detector kit.

The circuit solution is based on the Ramsey Electronics TD-1 kit which sells for \$9.95. (While one could get the parts through other sources easily enough, the Ramsey kit includes all the parts and a circuit board, thus making it very cost-effective.) It meets all the criteria of being inexpensive, reliable, a good club-night kit, easily setup with no test equipment other than a Volt-Ohm-Meter, etc. Rod Lane then developed the surrounding circuitry as shown in Figure One which causes the alert to latch so that if the user is out of the house when an alert is sent, when they come back there will be an alert indicator.

Theory of operation

The TD-1 does the tone detection. All that needs to be added is a simple double-pole, double-throw relay and a few other small, inexpensive parts. The Ramsey board will work on 12vdc, so that's what we'll want for a relay. The form of the relay isn't really an issue. Just about any relay will work. Those nice small reed relays work well, and it doesn't take much power to trip them.

One side of the relay goes to +12v. The bottom side goes to the Ramsey logic output. We'll need a diode backwards (cathode up to the +12v) across the relay to kill off any spike that'll come back from the relay as it's de-energized.

One half of the relay gives us the latching capability. Take the common of one side and wire it to ground. The N.O. (normally open) contact of that side hooks to the bottom (TD-1 side) of the relay. This way, once the TD-1 keys the relay, the contacts of the relay take over and keep it energized. The only way to reset the relay is with a switch on the 12v side of the relay to momentarily drop the current through the coil. It's a LOT cheaper than those latching relays.

Typically, I also put an LED and series dropping resistor across the relay so you get a visual indicator of when the relay is energized. This helps when you're tuning the TD-1.

You can do many things with the remaining side of the relay. It can set off a buzzer, turn on lights, or if you put it in line with the audio to a speaker on the scanner or radio you're

using as the receiver for the 1750 Hz tone. This way you'll hear all of the conversation subsequent to the tone alert. Not a bad idea actually.

Parts List

Ramsey Model No. TD1

Dual Tone Decoder Encoder Kit.

Cost \$9.95 each

Ramsey Electronics

590 Fishers Station Drive

Victor NY 14564

Phone (585) 924-4560

Fax (585) 924-4555

www.ramseyelectronics.com

Total Solder Points 37

Estimated Assembly Time for the TD-1 – 0.6 hours (perhaps more for beginners)

Required Tools: soldering iron and solder, needle nose pliers and small diagonal cutters.

Additional Parts List:

K1	Relay	RS-275-206
VR1	5k potentiometer	RS-271-1720
	Momentary normally closed switch	RS-275-1548
	LED	RS-276-330
	1k Ohm resistor	RS-271-1118
	1N4001 Diode	RS-276-1101
	Piezo Buzzer (optional)	RS-273-059
	Perf Board (optional)	RS-276-148
	Case (optional)	RS-270-1802
	Mini Phone plug (or appropriate plug to connect to speaker/earphone jack of radio)	RS-274-286

RS = Radio Shack. Equivalent parts are available from many providers

Schematic

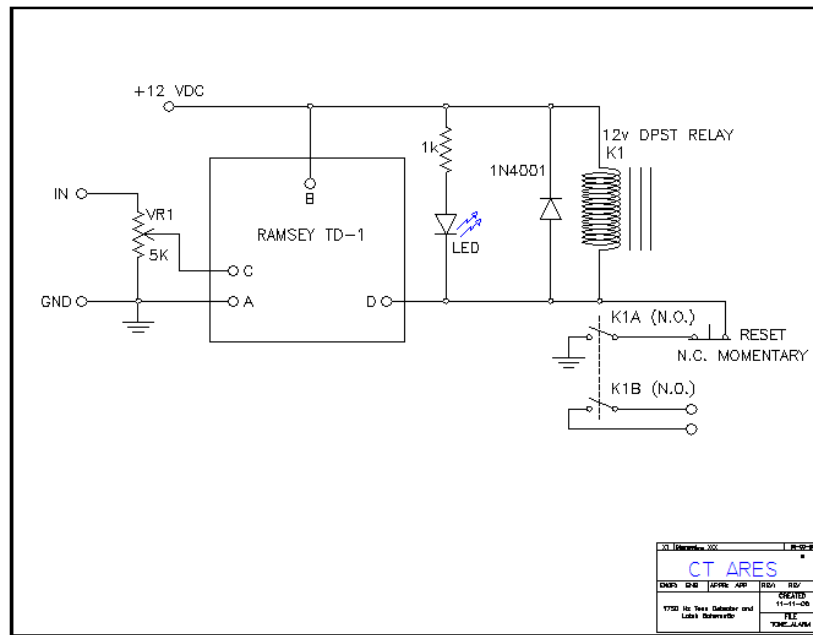

Construction

Construction is not critical as we are only dealing with audio frequencies. The additional components can be wired directly to the TD-1 or a piece of perf board could be used to mount the TD1 and the rest of the parts.

We hope that clubs and other groups will use this as a club project. If you would like an assembled unit and don't want to build it, you may want to watch for a club building these as a project and ask someone to build you one. Assembling the entire circuit is a one to two hour project for those with medium to high electronics experience.

Setup

When you initially power up your circuit, the relay will engage and buzzer will sound (if you have one) until you push the reset button to reset the relay latching circuit. If you have a frequency counter available that will go down to 1750 Hz, it'll dramatically simplify the alignment of the board. Attach the input of the frequency counter to test point "E" on the TD-1. Just tune the TD-1's multi-turn pot until you see 1750 Hz on the counter. If you don't have access to a counter, don't worry. The alignment below will help with tuning it up.

Next hook the circuit to your radio (or scanner). Set the volume control on the radio about 1/3 of the way up. Set VR1 to about half-way. If you don't have a frequency counter, do the following to set the operating frequency. Hold down the reset button and generate a 1750 Hz tone. Adjust the variable resistor on the TD1 until the circuit detects

the tone. Go past this point and count the turns until the LED goes out. Back it up half that number of turns. This way you're in the middle of the decoder's range.

With the frequency now set, back down VR1 until the relay drops out again. Advance VR1 up a little until the decoder reliably decodes the tone. This prevents overloading the detector and possible false signals. Release the reset button and you're ready to do some on-air tests. Some trial and error will be needed to set all of the levels, but this process should get you there reasonable quickly.

Conclusion

The idea behind this project is that many people have a scanner or old radio they can simply leave listening to the local ARES frequency with the hardware tone decoder plugged in. We feel that the tone detector is a good way to provide 24x7 alerting that does not rely on commercial telephone systems.